

Operation

A. TO RAISE HOIST

1. Start Engine in neutral – Park Brake
2. Depress the clutch and engage the P.T.O.
3. Release the clutch and open the hydraulic valve.
If the pump squeals, oil is by-passing in the valve and indicates maximum pressure.
By-passing can occur.
 - At the extreme end of cylinder travel
 - If hoist overloaded or jammed and not allowed to work freely
4. Do not rev the truck engine to an extremely high RPM because a piston pump that operates over 1000 RPM will be damaged, a gear pump can operate to 1500 RPM.

B. TO LOWER HOIST

1. Push the dash control to open valve. BE CAREFUL – Do not lower heavy loads quickly or damage to the hoist or truck can occur.
2. Disengage the P.T.O. when dumping cycle is completed, otherwise the pump wears needlessly, and the drive and pump can be damaged.

Maintenance

1. Check that all hydraulic hose connections are tight.
2. Check your pump reservoir oil level. Keep dirt and other foreign material from getting into your hydraulic system, oil should be changed once a year.
3. Check all welds and bolts to ensure that all connections are secured.
4. **Grease your hoist regularly.**



CAUTION



When greasing or checking hoist in its open position, always block the truck box so that it cannot come down.

Trouble Shooting

Hoist not operating properly

- Hydraulic hoses may be kinked or pinched.
- Insufficient oil in reservoir.
- The power take-off is not working.
- Pump not working, cable control may not be set properly and not operating the pump valve correctly.
- Pump relief valve is not set properly and the pump is not developing required pressure. Check pressure, if not proper return pump to factory.
- Hoist is overloaded, check weight of load and hoist rating at that particular mounting distance and box overhang. (See capacity chart)
- Severe cold spell and the hydraulic oil used is too viscous or heavy; use transmission fluid.
- Noisy operation – drive shaft too long - may require a steady bearing; U-joints are not aligned properly - check that the pins on each yoke are parallel to each other.
- Hoist operation is not smooth, or spongy – bleed air from hydraulic system by operating hoist up and down.
- Truck box long beams are not strong enough and under load are bending, twisting and jamming the hoist and preventing it from working freely – stiffen sills and put in a cross-member to stop the sills from twisting.
- Hoist not installed level but hanging down below top of truck chassis – hoist will not develop full power.

Installation Instructions

Read and understand the operating and installation instructions fully, before installing or operating the hoist.

The following items are **NOT INCLUDED** with the hoist and are required to complete the hoist and box installation:

- P.T.O. and control cable
- Truck chassis spacer (See Fig. 2 & 3)
- Truck box long beams (See Fig. 2)

1. LOCATE TRUCK BOX REAR HINGE POSITION on truck chassis, as close as possible to the rear spring hanger, **NOT OVER 6" ON A SINGLE AXLE TRUCK**, this would be approximately 33" to 36" behind the center of the rear axle. On Tandem Axle trucks, the center of the hinge should be approximately 45" to 53" behind the tandem trunnion center.

NOTE: If a distance of 53" is exceeded between the rear hinge and the center of the trunnion on tandem axle trucks and a distance of 36" on single axle trucks additional reinforcement of the truck frame is required.

Mark rear hinge position. **DO NOT INSTALL HINGE ASSEMBLY** at this stage.

Insert cylinder into hoist trunnion and fasten with 4-1/2" nuts and lockwashers (Items 11 & 12). Attach cylinder rod clevis to upper cross tube with 2 – clevis caps and bolt using 8-1/2" x 1 1/2" Hex head bolt, 1/2" Nylock nut and spring lock washer. (Items 9 & 11)

NOTE: Clevis must rotate freely around cross tube.

2. PLACE HOIST LEVER ON TRUCK CHASSIS at the position of desired tilt angle. (See capacity chart). The hoist can be mounted, depending upon clearances on the truck chassis, two different ways, as shown in the hoist-mounting diagram.

- (A) Conventional Position – Hoist pivot towards cab
- (B) Reverse Position – Hoist pivot towards truck axle

Once hoist position is determined check to see that the cylinders do not interfere with any part of the truck when the hoist is operated, see Hoist Mounting Diagram, Dimension "C". Then attach the hoist to the truck chassis with chassis angle (Item 8) and bolts provided. Fig. 2.

IMPORTANT: The hoist lever when resting on the truck chassis in the closed position should be supported so that it sits fairly level. If a truck chassis cross member does not exist to support the weight of the hoist, a cross member should be installed as shown in Fig. 1. A section of channel or angle iron may be used.

After the hoist lever is bolted in position, **WELD CHASSIS ANGLES** (Item 8) to chassis pivot brackets (Item 3) Fig. 2

DO NOT WELD TO THE TRUCK FRAME FLANGES – it will weaken the truck frame.

3. INSTALL THE HYDRAULIC SYSTEM The hydraulic system is **SINGLE ACTING**, i.e. the hoist is powered up only; the cylinder retracts under the weight of the box.

Place the hydraulic pump in an appropriate place, as close as possible to the P.T.O. where it will not be interfered with and where the hydraulic hoses and drive shaft reach. The drive shaft should be as short as practical except in a direct mount pump installation.

The piston pump and or gear pump, provided by Nordström, rotate in either direction, and should be mounted securely and in proper alignment with the P.T.O.

Attach slip u-joint to the pump shaft, and tighten securely. When attaching slip u-joints to the drive shaft, **DO NOT TIGHTEN, ALLOW IT TO SLIP** as the truck bounces, otherwise the pump may be damaged. **THE PINS ON THE YOKES OF THE U-JOINTS SHOULD BE PARALLEL** to each other, otherwise vibration may occur.

4. INSTALL CHASSIS SPACER AND REAR HINGE (Fig. 2 & 3)

HOIST: NTL 4.5-3

Mounting Direction	(See Fig. 1 (A) or (B))
Maximum Hoist Height:	9 1/2"
Body Cross Sills Min. Size Required:	4"
Body Long Beams Min. Size Required:	8"
Chassis Spacer Thickness Min:	1"
Unibody Min. Clearance	10"

FASTEN THE SPACER TO THE TRUCK CHASSIS. The spacer may be 1" wood or 1" x 2" x 4" long steel lugs. If steel lugs, use approximately four per truck side or a total of eight. Locate one at the rear hinge, one over the truck axle, one at the front of the box and one evenly spaced between the two. If wood is used then it should be the full length of the chassis.

DO NOT WELD TO TRUCK FRAME FLANGES – it will weaken the truck frame.

Install the truck box rear hinge weldment flush with the top of the spacer by notching truck chassis, aligning evenly and squarely and welding with a low hydrogen electrode. Fig. 3.

5. INSERT THE UPPER ARM SWIVEL BRACKETS (Item 2) and **TUBE SPACER** (Item 6) into the hoist lever. Fig. 2.

If the truck box long beams are already attached to the truck body then position the body on the truck chassis. If the truck box long beams are not supplied with the truck box, then place the long beam channel on the truck chassis **WITH THE FLANGES FACING OUT**. Shown in Fig 2.

CAUTION: BLOCK TRUCK BODY SECURELY WHILE INSTALLING OR SERVICING HOIST.

With the long beams resting on the rear hinge pivot platform, weld long beams to rear hinge. Both sides. See Fig. 3.

Secure upper arm swivel brackets (Item 2) to the truck box long beams by welding. **POSITION TUBE SPACERS** (Item 3) against hoist upper cross tube and stitch weld tube spacer to upper arm swivel bracket tube. Fig. 2.

To stiffen the truck body long beams and prevent them from twisting, **WELD A CROSS-MEMBER** (Item 5) between the upper arm swivel brackets as close as possible to the upper arm swivel bracket tubes (Item 2). Fig. 2.

6. Fill the pump with light hydraulic oil. **SLOWLY OPERATE THE HOIST AND CHECK THAT IT RUNS FREELY**, that the hydraulic fittings and hoses do not catch or rub on sharp objects, and that the hoses are long enough to allow the hoist to fully open. Run it up and down to bleed the air from the system. Add hydraulic oil. **DO NOT OVERFILL.** The hydraulic system is single acting and all the oil in the cylinder is pumped back to the tank.

7. GREASE ALL PIVOT POINTS. Plenty of grease is required in the initial lubrication; fill cavities completely. Regrease after first day's operation.

8. CAUTION DECALS are included in the hoist mounting kit. Attach the two caution decals (Block Truck Body Safely Before Servicing Hoist), to either side of the truck body in a position where they can be readily seen. Place the two remaining decals, on the dashboard near P.T.O. and pump control knobs. Read and fully understand all the items in the caution decals, and the operating and maintenance instructions before operating the hoist. **USE THE HOIST RESPONSIBLY AND SAFELY**

9. The distributor or seller of the hoist must make certain that the truck owner receives the **Nordic Operators Manual**.

HEAD OFFICE:

5 Chester Street
 Winnipeg, Manitoba
 Canada R2L 1W5
 Phone: 204-667-1553
 Fax: 204-663-8497
 Email: wpghoistsales@nordstronqequipment.com

DISTRIBUTION CENTRE:

#703 - 19TH Avenue
 Nisku, Alberta
 Canada R2L 1W5
 Phone: 780-454-3430
 Fax: 780-454-6224
 Email: niskuhoistsales@nordstronqequipment.com

Model NTL 4.5-3 Twin Telescopic Hoist

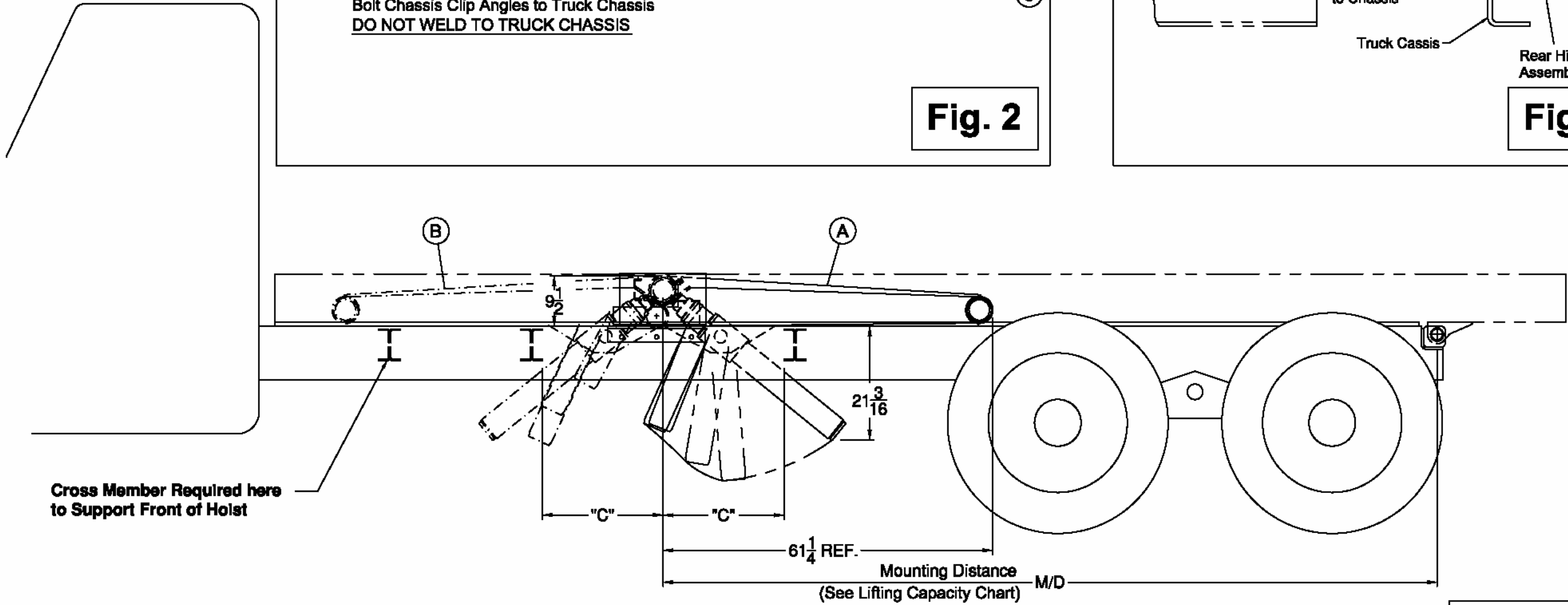
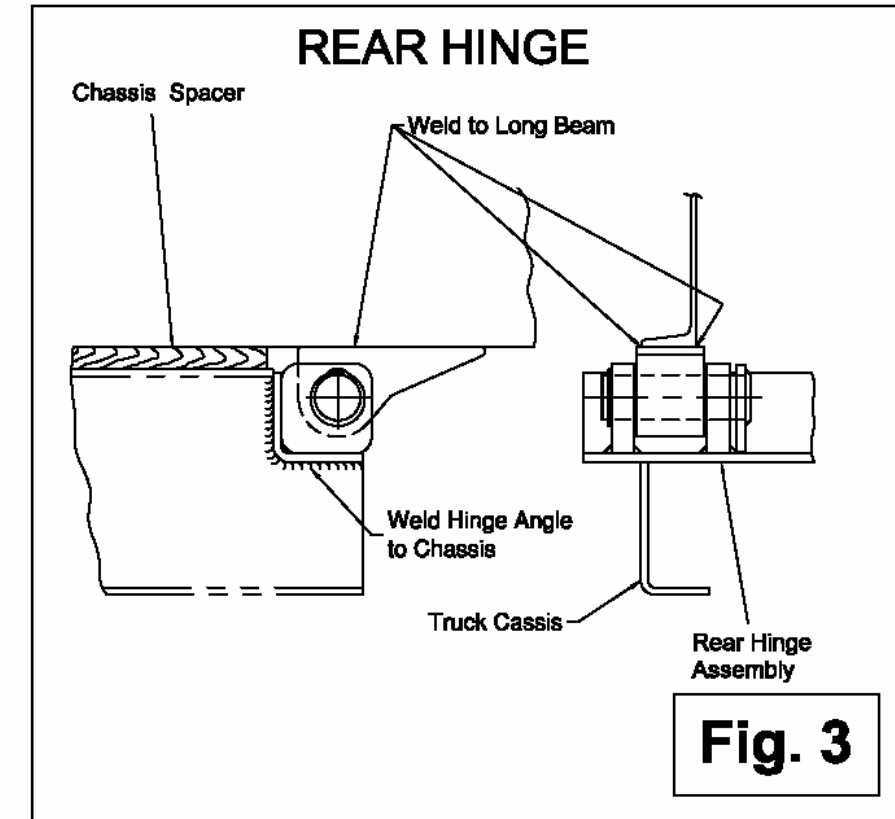
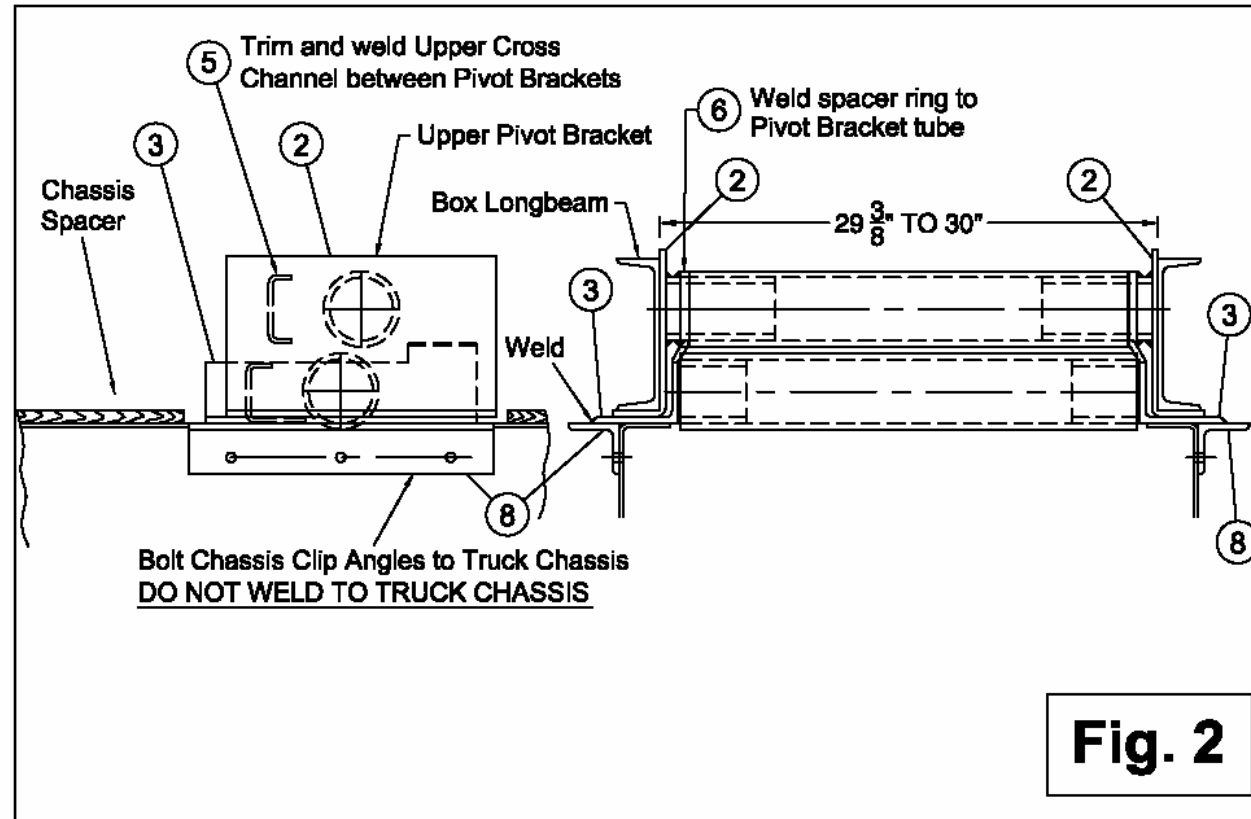

"C" = 20" Clearance req'd for
 Cylinder Movement

THE NTL 4.5-3 HOIST CAN BE
 MOUNTED IN EITHER DIRECTION

Fig. 1

HOIST MOUNTING DIAGRAM



HOIST LIFTING CAPACITY

Model (NTEA Classification)	BL (Body Length) (Ft.)	CT (Ins.)	OH (Body Overhang) (Ins.)	Capacity Key No. 23	Tons at Dump Angle Body & Payload				
					40°	45°	50°	55°	60°
NTL 4.5-3	20'	180"	18"		36	32	29	27	24
@3500 P.S.I.	20'	174"	24"		38	34	31	28	26
Conversion = J	22'	198"	24"		34	30	27	25	23
Dump Body = 100	22'	192"	30"		36	32	29	27	24
	22'	204"	18"		32	29	26	24	22
	24'	210"	36"		33	29	26	24	22
	24'	222"	24"		30	27	25	23	21
Approximate mounting distance					161"	144"	131"	120"	110"

Tandem Axle – Capacity based on an evenly distributed load, a 3" truck box to cab clearance, and a truck box pivot location of:

- leaf spring suspension 45" behind the center of the tandem trunnion
- air suspension 53" behind the center of the tandem trunnion

CAUTION:

The combined weights of the truck chassis hoist and platform (or body) and cargo must not exceed the gross vehicle weight rating (GVWR) of the truck.

To Calculate Lift Capacity:

$$\text{Lift} = \frac{\text{M.D.} \times \text{Capacity Key No. (from Chart)}}{\frac{1}{2} \text{ BL-OH}} = \text{Tons}$$

MD – Hoist Mounting Distance (Inches)

BL – Body Length (Inches)

OH – Body Overhang (Inches)

NTL 4.5-3 HOIST SPECIFICATIONS	
No. of Cylinders	2
Cylinder Bore (inches)	4.5
Telescopic Cylinder Stroke (inches)	91
Mounting Height (inches)	9 ½
Recommended Long Beams (inches)	8
No Body Cross Sills (inches)	10
Weigh – Approx. (Pounds)	928

Warranty

Nordstrong Equipment Limited is very proud of the high quality of our **Nordic** underbody truck and trailer hoists and front mount telescopic cylinders. We are industry leaders in design and manufacture and we stand behind the reliability of our products.

It is our policy to replace any part(s) free of charge, FOB the factory, for any parts returned (freight prepaid) and judged by **Nordstrong Equipment Limited** to be defective due to material or workmanship. **Nordstrong Equipment Limited** will warrant all **Nordic** double acting underbody hoists for a period of three years, and all **Nordic** single acting telescopic hoists for a period of two years, from dealer point-of-sale to the end user.

Non-standard usage or abuse of products, or unauthorized modification, repair or alteration will void the warranty.

Nordstrong Equipment Limited will not assume responsibility for loss of time, manufacturing cost, transportation cost, or loss of profits, as a result of defective products.

Items that are not manufactured by **Nordstrong Equipment Limited** are therefore covered by the warranties of the suppliers of these items. We will therefore extend, without assuming any responsibility, any warranty given to us by our suppliers, subject to the terms of such warranties.