



INDUSTRIAL BUCKET ELEVATORS

GUARANTEED PERFORMANCE, RELIABLE, RUGGED SERVICE

NORDSTRONG Industrial Bucket Elevators are available in a wide variety of designs for today's toughest applications. We offer purpose built, custom engineered equipment to elevate a diverse range of bulk material, ranging in size from very fine powders to large lumps.

The selection of the proper type bucket elevator depends largely on the capacity required and the characteristics of the material to be handled. Let us choose the style that works best for you.

Available with multiple options and backed by 100 years experience as one of the most exclusive producers of bulk material handling equipment. Nordstrong Bucket Elevators can be relied upon to perform under the most adverse conditions.

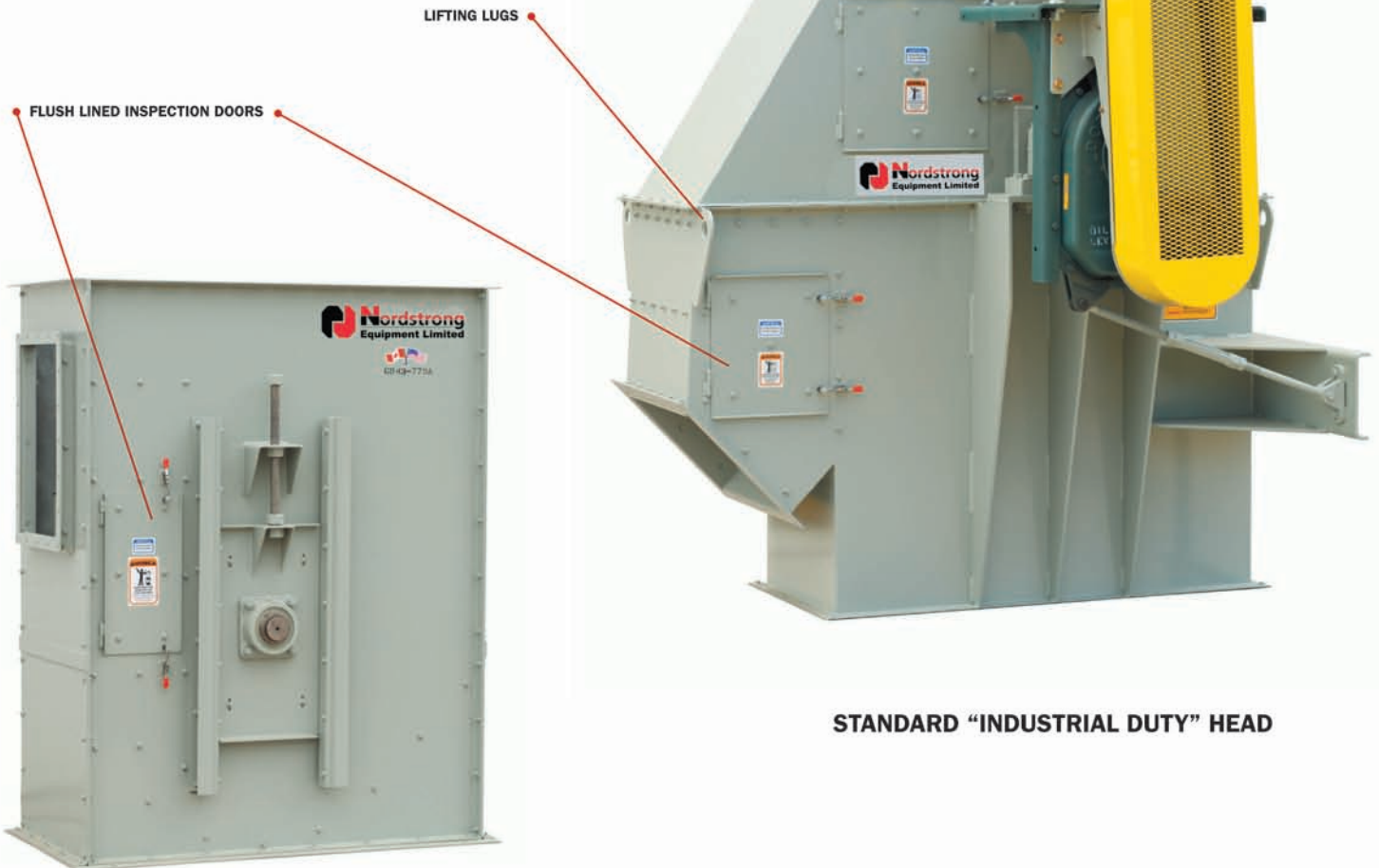

LIFTING LUGS

FLUSH LINED INSPECTION DOORS

STANDARD "INDUSTRIAL DUTY" HEAD

SCREW TAKE-UP BOOT

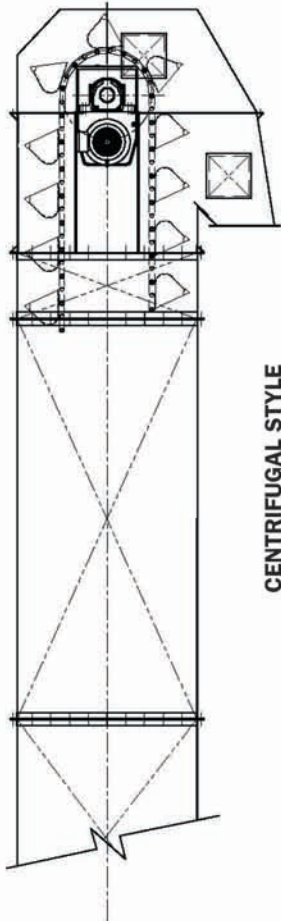

CENTRIFUGAL STYLE

Nordstrong Industrial Bucket Elevators are available in two general categories. Standard "Industrial Duty" and Heavy "Mill Duty". Industrial Duty units can be either centrifugal discharge or continuous style. Both types can be furnished with chain or belt mounted buckets.

INDUSTRIAL CENTRIFUGAL TYPE

Recommended for handling relatively fine free-flowing and loose bulk materials with small to medium sized lumps. Material is discharged by centrifugal action as the interval spaced buckets pass over the head wheel.

Loading is accomplished by directly feeding material into the buckets at the inlet.

Belts are preferred for more abrasive applications, providing high temperatures are not a factor.



AA CENTRIFUGAL WITH AR LIP

CONTINUOUS TYPE

The continuous discharge elevator is used to handle sluggish, aerated material or product having a large percentage of lumps. Mounted continuously on either belt or chain and operating at much slower speeds, the buckets form a chute as they pass around the sprocket or pulley. Gravity causes the material to fall gently onto the back of the preceding bucket and out of the discharge spout.

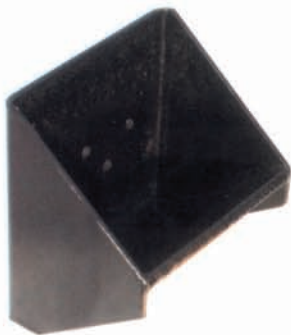

MF CONTINUOUS WITH AR LIP

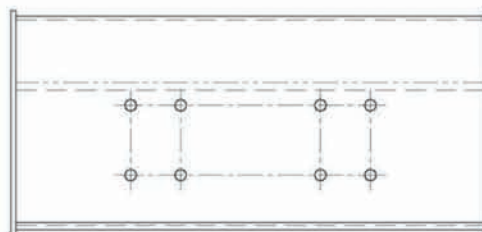

AC WELDED STEEL BUCKET

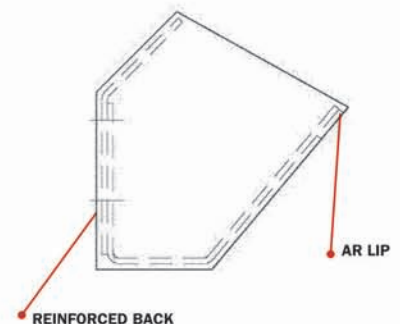

REINFORCED BACK

AR LIP



HEAVY MILL DUTY INDUSTRIAL ELEVATORS

First designed and commonly known as “Cement Mills”, these elevators meet the most severe bulk material handling requirements. Now used for a variety of high capacity and abrasive applications, their design and durable construction make them ideal candidates for the toughest environmental conditions.

Usually mounted on a single strand of steel bushed chain, AC or SAC buckets travel at speeds high enough for a clean centrifugal discharge.



AR LINERS

75 HP CEMENT MILL

SJ TYPE

Developed as an alternative to meet the needs of today's industrial type elevators, particularly cement, this high performance heavy gauge pressed seamless steel bucket is designed and engineered to replace large fabricated buckets. Compared to traditional chain and bucket formats it offers substantial increased in capacity relative to the casing size of conventional elevators. Capable of running at speeds up to 430 F.P.M. with throughput in excess of 1000 T.P.H., it is ideally suited for high capacity/ high lift applications and provides unequalled opportunity to upgrade existing equipment. Also available with reinforced wear lip, it is closely mounted on standard rubber or steel-web belt for ultimate performance.



SUPERCAPACITY type elevators are more suited to handling friable, heavy or abrasive materials at very high capacity and can accommodate very large lumps. The massive ‘H’ style buckets are end-mounted continuously between two strands of high quality steel bushed roller chain.

Material is fed to the buckets through an internal loading chute. Extremely low speeds guarantee true continuous discharge and ensure long-life.



SPLIT GLAND SEALS

EXTERNAL GRAVITY TAKE-UP



NORDSTRONG CONSTRUCTION FEATURES

FOR RELIABLE, EFFICIENT, DEPENDABLE PERFORMANCE

HEAD SECTION

- Factory assembled
- Roller bearing pillow blocks
- Adjustable bearing pedestals
- Weather tight inspection doors with regreasable hinges
- Adjustable throat baffle
- Split hood with shaft seals
- Crown faced double disc drum pulley with vulcanized lagging or hardened tooth sprocket
- Optional split, segmented sprocket or traction wheel

BOOT SECTION

- Factory assembled
- Externally mounted flange or pillow block bearings
- Acme screw take-up with shaft seals
- Optional gravity take-up with internal hard iron bearings (available with stellite sleeves)
- Hinged and bolted access panels
- Boot inlet
- Crown faced double disc drum or wing pulley, or matching sprocket/traction wheel combination

CASING

- Heavy gauge construction to suit any application
- Jig welded with continuous seams and structural angle iron flanges
- Oversize hinged and bolted inspection doors

DRIVES

- Standard or customer specified drives for all models.

OPTIONAL FEATURES AND ACCESSORIES

- Stainless steel construction
- Special paints
- Head take-ups
- Special designs for various environmental conditions

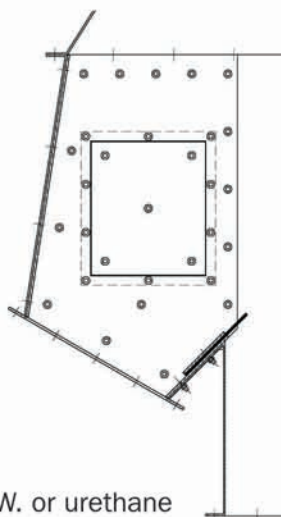

LINERS

- U. H. M. W. or urethane
- AR 225 or 400 Bhn. steel
- Overlay plate

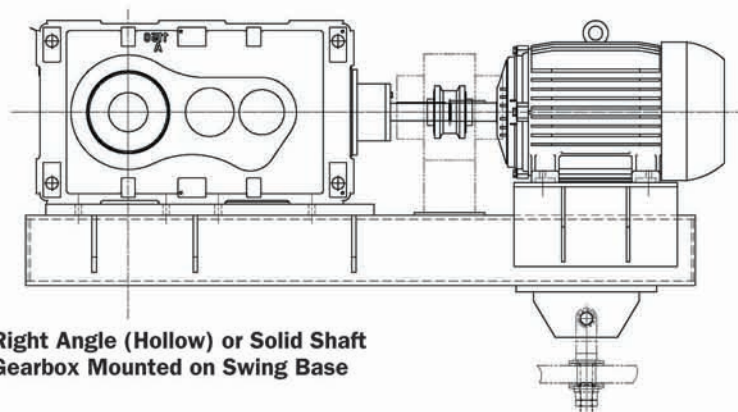

Right Angle (Hollow) or Solid Shaft Gearbox Mounted on Swing Base

LADDERS AND PLATFORMS

- Standard or custom platforms
- Step off, rest and valve service platforms
- Bolted or welded O.H.S.A. caged ladders

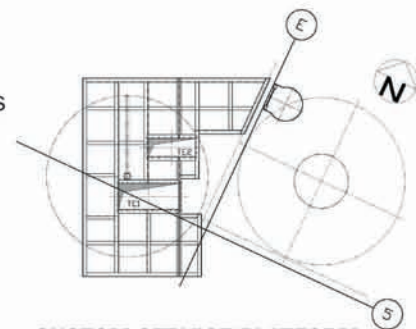

CUSTOM SERVICE PLATFORM